



MS-5010B Ultrasonic Foil Splicer

Splices aluminum and copper foils neatly and quickly by creating true metallurgically bonded seam welds.

General Description

The Sonobond Model MS-5010B Foil Splicing Machine is the fastest and cleanest way to join aluminum foils up to 0.006 inch thick and 72 inches wide.

The model MS-5010B splicer consists of a power unit with a solid-state frequency converter, a welding head, and a rotating disk tip which traverses the width of the foil at speeds up to 15 feet per minute. Welding rate depends on the thickness and type of alloy being joined. It can be easily fitted to most foil mill separating and splicing machinery.

The model MS-5010B splicer produces fine ultrasonic seam welds with effective metallurgical and dimensional characteristics similar to the original metal foil. This facilitates additional foil processing such as rerolling, laminating and printing.

The world's leading manufacturers of aluminum and copper foil products prefer the Sonobond Model MS-5010B foil splicer. They are in use in practically every aluminum foil mill in the United States.

Features and Benefits

- Neat, clean seam welds in foils up to 6 mils thick
- Consistent flawless splices in foils as thin as 0.00017" (0.004mm)
- Normal degreasing with no post cleaning
- Up to 20 times faster than other splicing methods
- No heat or thickness distortion of materials
- No fluxes, filler metals, tapes or other consumables
- Low energy consumption (70 watts)
- Minimal operating and training costs
- Automatic frequency control for stable operation
- Ultrareliable solid-state metallurgical bonds

Applications

The Sonobond Model MS-5010B foil splicer is the perfect solution for any foil splicing application. The systems are usually used in copper and aluminum foil manufacturing processes where they become an integral part of utility foil mill operations. The fast splicing rates have made every other method of splicing literally obsolete.



Theory of Operation

Sonobond MS-5010B ultrasonic foil splicing machines produce seam welds through the momentary application of mechanical vibratory energy under pressure.

The ultrasonic seam weld occurs in the solid state with no melting of the materials. Nothing resembling the cast structure of a fusion weld results. Inspection of ultrasonic welds produced by the Model MS-5010B Foil Splicer shows no essential difference between the structure of the weld zone and the adjacent parent material.

Foil Materials and Welding Speed

Ultrasonic welds between sheets of the same metal alloy and gage show joint strengths approaching 100% of the parent metal strength.

The Advantages

The following foil materials are accommodated by the Sonobond Model MS-5010B Ultrasonic Splicer.

Material	Thickness (in inches)	Welding Rate (feet per minute)
Aluminum (1100-H18)	0.001	15.0
	0.003	5.0
	0.006	1.5
Copper	0.001	5.0
	0.002	1.5

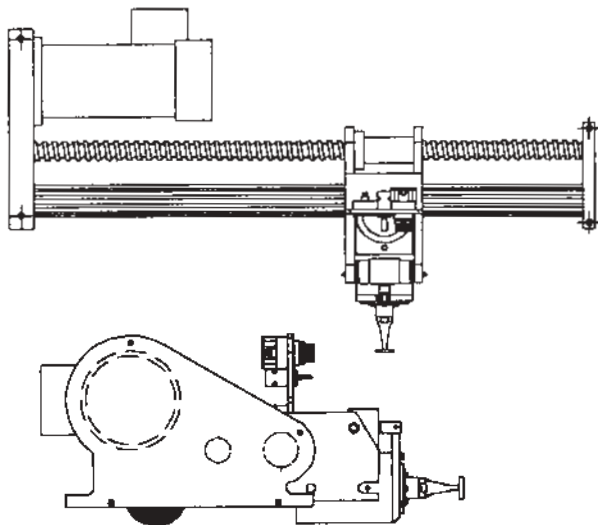

Optimum Performance

Our Model MS-5010B Ultrasonic Foil Splicer has it all. This is the model that takes the technology to a level of performance unique in our industry...for consistent high quality splicing of the very thinnest foil...as thin as 0.00017" (0.004mm). Its low amplitude, 50 kHz design yields a relatively inconspicuous metallurgical splice with linear conformity from edge to edge. The new 5010B system can even be retrofit into existing, older model Sonobond splicers. No other foil splicer comes close in performance or flexibility.

Automatic Frequency Tracking Upgrade

Our power supply, the FC5010B, features a 100% automatic frequency tracking system based on a unique phase-lock loop circuit. It eliminates the need to manually adjust the frequency for peak operation and works with any Sonobond foil splicer equipped with a piezoelectric ceramic transducer.

Specifications

Welding Head

- Clamping Force Pneumatic clamping variable up to 20 pounds
- Input Power 70 electrical watts
- Mechanical Trunnion mounting frame, clamping force system, and variable speed drive for head rotation
- Welding Rate Up to 15 feet per minute
- Length of Traverse Up to 72 inches
- Size (approx.) 9" deep, 5" wide, 4" high
- Weight (approx.) 12 pounds (without drive mechanism)
- Electrical 120 volt, 10 ampere, single-phase
- Air 2 scfm clean dry air at 60-80 psi

Power Supply

- Frequency Nominal 50 kHz with Automatic Frequency Control
- Power Output 70 watts into a matched resistive load
- Size (approx.) 14" wide, 8" high, 15" deep
- Weight (approx.) 20 pounds

Specifications are provided for information only and are believed to be accurate. However, no responsibility is assumed by Sonobond Ultrasonics for their use. Ongoing product development and improvement may cause changes without notice.

SONOBOND[®]
ULTRASONICS

INDUCTOTHERM INDUSTRIES, INC.

SONOBOND ULTRASONICS

1191 McDermott Drive • West Chester, PA 19380

Phone: 800-323-1269 • 610-696-4710 • Fax: 610-692-0674

Internet: www.SonobondUltrasonic.com

Email: Sales@SonobondUltrasonic.com